

Darwin

Mist Collector



Darwin

Darwin series is a range of centrifugal filters for cleaning air containing oil mists, micro-mists and smokes produced when using coolants (emulsion or neat oil).

It can be used with a majority of machine tools for all machining processes.

It is available in 4 sizes with three different, interchangeable filtration technologies.

Throughputs available are from 600 to 3.000 m³/h, with different combination for increasing filtration efficiency, up to 99,97%.

Patented in USA and in Europe

(Italy, France, Germany, UK, Luxemburg, Switzerland, Sweden, Spain).



LOSMA grants that every single system is tested through strict control procedures. Every unit is provided with a qualitative and functional test certificate.



Working principles

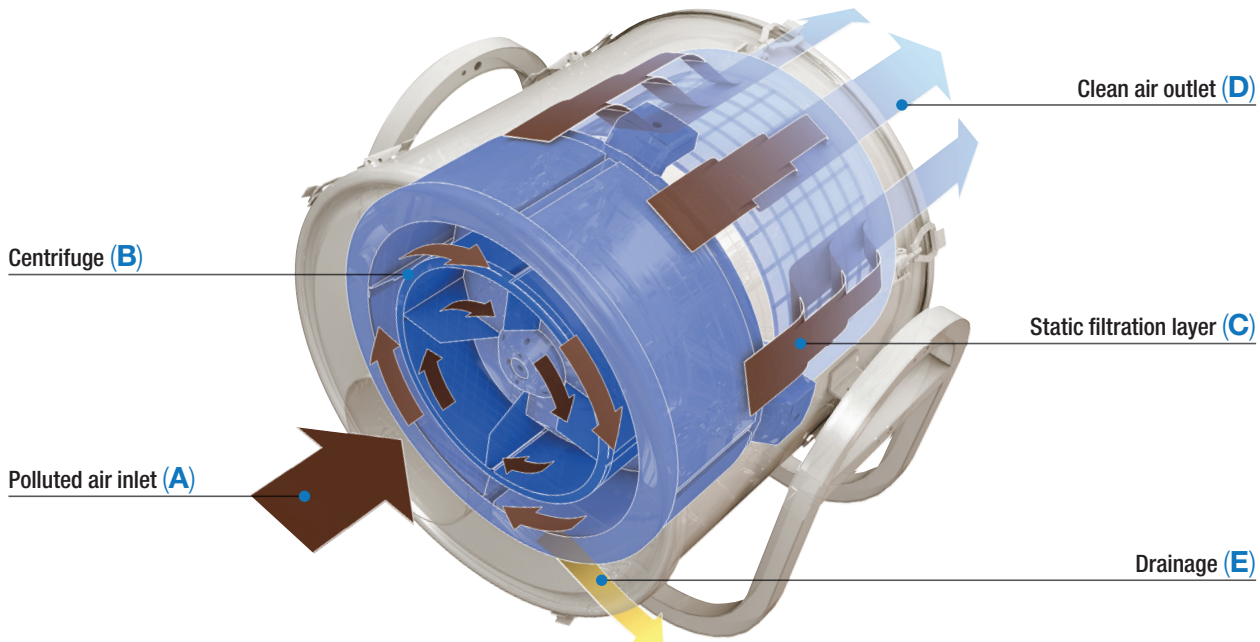

- 1** Polluted air is drawn into the system (A) thanks to the depression generated from the rotation of the centrifuge (B), which gives the air a swirling movement.
- 2** Air passes through the special expanded polyurethane foam inserts positioned in the centrifuge (only in mono and double version) and then into a net. The combination of all these elements facilitates the re-coalescing of oil particles - including the finer ones.
- 3** Air crosses a further static filtration layer (C) before being re-introduced into the working environment (D). The re-condensed liquid is eliminated through the drainage tube in constant positive pressure (E).
- 4** Darwin series grants a filtration efficiency of over 95%, also for pollutant particles below one micron; this efficiency rate can be increased to 99,97% with the use of an absolute post-filter (HEPA FILTER) according to EN 1822 norms.



Turbine

Suitable for surface machining (sharpeners, grinders, honing, lapping and similar finishing processes) also in the presence of heavy particulates.



Mono centrifuge

Suitable for all machining processes (emulsion or neat oil).



Double centrifuge

Suitable for all machining processes (emulsion or neat oil) in particular for heavy machining conditions such as use of high pressure which generates micro-mists and vapours.

Plus

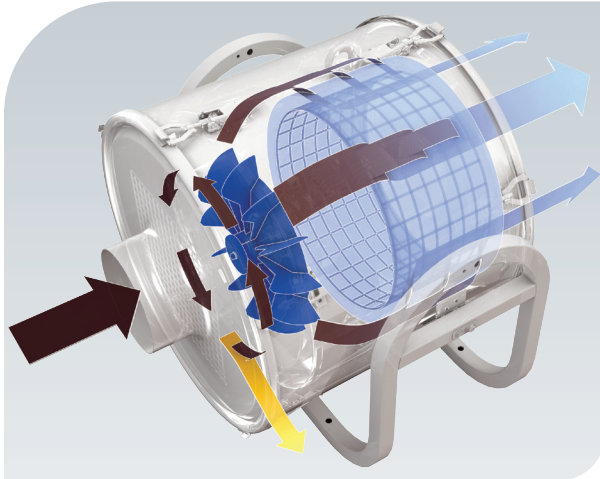

TWO-STAGE FILTRATION

Darwin series uses a double filtration combination: dynamic (given from centrifuge rotation) and static (with integrated post-filtration system) to grant high performances.



CONDENSATION AND DRAINAGE

Compared to the most common static air filtration systems, Darwin series grants incomparable capacity of re-condensation and drainage; overpressure inside the filter is used to continuously discharge coolant which may then be collected and recycled.



VERSATILITY AND MODULARITY

Darwin series, unique in its category, offers 12 different combinations of filtration technologies and corresponding aspiration power, facilitating the choice of a suitable solution for all requirements,

so avoiding energy waste caused by over-sized systems or, on the other hand, inefficiency caused by under-sized systems.



EASY INSTALLATION

All Darwin systems can be mounted either horizontally or vertically thanks to an exclusive cradle, which allows the filter to rotate on its axis and also allows installation in very small spaces.



QUICK AND EASY MAINTENANCE

Access to the filtering section is very easy and immediate and does not require unscrewing or disassembly of any parts. Simply open the cover which is shut with pressure hooks to access the filters. They can be extracted and changed very easily and quickly.



STAINLESS STEEL VERSION

All Darwin series models can be supplied in stainless steel, in order to be used in applications where painted steel is not ideal.

Optional

Filter clogging X-VIEW sensor

The new X-VIEW sensor is able to detect the progressive clogging state of the Darwin filters, signalling three main operating phases (Led version):

- GREEN: Clean Filters;
- YELLOW: Pre clogging;
- RED: Clogging.



Patent application filed

Also thanks to an exclusive software, it is possible to detect possible ANOMALY conditions:

- Upstream obstructions (piping, grid, etc.);
- Zero flow.

Thanks to an integrated TIMER, X-VIEW sensor allows to know when 15,000 working hours (ex. 5 years/ 8 hours per day) have been achieved, which is the recommended threshold for the check of the filter set.

X-VIEW sensor can be positioned on Darwin or in any other part of the machine tool where the operator is more comfortable reading the data.

Thanks to the Self-learning button, it automatically sets itself to the initial values, making installation extremely easy.

From that time, all flow changes are measured according to the GREEN, YELLOW, RED scale.

X-VIEW works with all accessories (Guard; Clipper) and it can be integrated with the CNC of the machine tool (IoT Ready version), providing feedback in real time on the air filter conditions.

The sensor comes in two versions:

X-VIEW Led version

Through a luminous signal it shows:

- the filter clogging status: Clean Filters - Pre-clogging - Clogging.
- Possible upstream obstructions: instantaneous or progressive obstructions of the inlet pipe or suction grid in the machine cabin (e.g. chip or liquid build-up).
- Zero flow alarm: e.g. Darwin turned off, motor not working or turned off, piping disconnected).
- Timer: It indicates the achievement of 15,000 working hours (the threshold recommended for check of filters).

X-VIEW IoT Ready version

- Transmission of data directly to the CNC machine by cable related to:
- The filter clogging status: Cleaned Filters - Pre-intasamento - Clogging.
- Possible upstream obstructions: instantaneous or progressive obstructions of the inlet pipe or suction grid in the machine cabin (e.g. chip or liquid build-up).
- Zero flow alarm: e.g. Darwin turned off, motor not working or turned off, piping disconnected).
- Timer: It indicates the achievement of 15,000 working hours (the threshold recommended for check of filters).
- Remote or CNC control:
- Configuration conditions: possibility to configure the main monitoring parameters in real time.
- Re-setting of the alarms.
- Timer resetting.
- Zero flow.

Technical data

X-VIEW LED

- Voltage: 24V DC
- Signal type: LED display
- Size: Dimensions: A = 110 mm
Ø = 115 mm

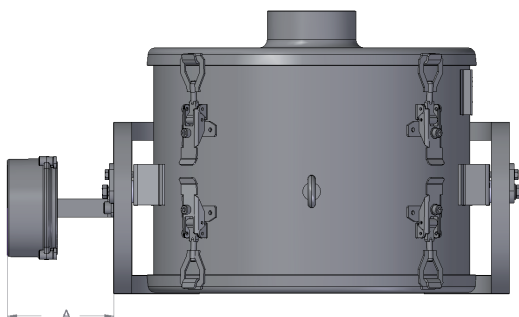

X-VIEW IoT Ready

- Voltage: 24V DC
- Signal type: Digital
- Size: Dimensions: A = 110 mm
Ø = 115 mm

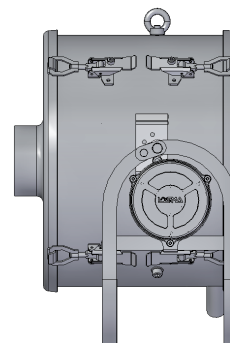

Optional

Clipper

Available with F9 filtration level (95%) or H13 efficiency, up to 99,97% following EN 1822 norms. Useful in case of micro-mists and smoke.

Guard

Pre-Filtration module for swarf, chips and dust, working through metallic and synthetic filtration stages.

Useful to optimize the air suction efficiency in case of high production of oil mists containing dusts and metallic swarf chips.



Installations



Technical data

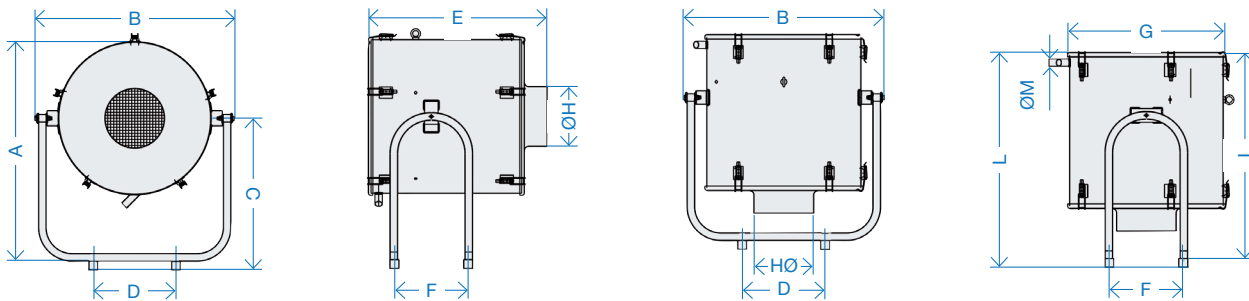

MODELS	Dimensions (mm)										
	A	B	C	D	E	F	G	Ø H	I	L	Ø M
Darwin 600	487	457	300	180	324	170	365	100	382	412	25
Darwin 1200	563	574	428	275	460	245	457	150	589	619	25
Darwin 2000	563	574	428	275	510	245	457	150	614	644	25
Darwin 3000	576	665	505	275	594	245	523	200	684	714	25

MODELS	Flow Rate*		Noise level (dba)	Inlet (mm)	RPM (rpm)		Net Weight (kg)	Power (kW)	
	50 (Hz)	60 (Hz)			50 (Hz)	60 (Hz)		50 (Hz)	60 (Hz)
Darwin 600 T	600		72	100	2800	3400	21	0.37	0.43
Darwin 600 M	600		67	100	2800	3400	21	0.37	0.43
Darwin 600 D	600		67	100	2800	3400	21	0.37	0.43
Darwin 1200 T	1350	1650	76	150	2800	3400	35	1.50	1.75
Darwin 1200 M	1270	1500	76	150	2800	3400	35	1.50	1.75
Darwin 1200 D	1270	1500	76	150	2800	3400	35	1.50	1.75
Darwin 2000 T	1920	2370	78	150	2800	3400	39	2.20	2.55
Darwin 2000 M	1950	2430	78	150	2800	3400	39	2.20	2.55
Darwin 2000 D	1800	2180	78	150	2800	3400	39	2.20	2.55
Darwin 3000 T	3000	3300	79	200	2800	3400	62	3.00	3.45
Darwin 3000 M	2900	3200	77	200	2800	3400	62	3.00	3.45
Darwin 3000 D	2900	3200	76	200	2800	3400	65	3.00	3.45

* Free inlet

Standard voltage: 50 HZ 230V/400V - 60 Hz 265V/400V

Guard + Darwin + Clipper

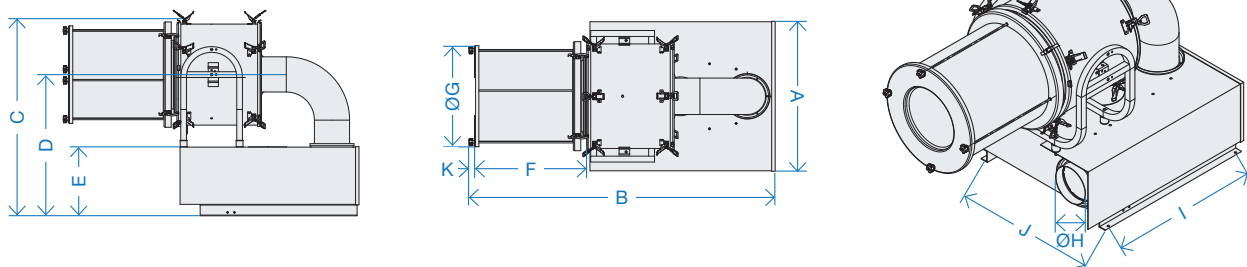

ASSEMBLY	Dimensions (mm)										
	A	B	C	D	E	F	ØG	ØH	I	J	K
Guard 10+Darwin 600+Clipper	560	1074	860	612	300	363	365	98	542	513	19.5
Guard20a+Darwin 1200+Clipper	655	1338	860	618	300	483	407	148	642	608	19.5
Guard20a+Darwin 2000+Clipper	655	1364	860	618	300	483	407	148	642	608	19.5
Guard30a+Darwin 3000+Clipper	655	1382	905	631	300	388	523	198	765	608	19.5

Notes





Health



Savings



Efficiency



Environment



Safety



Losma SpA

HQ:

Via E. Fermi, 16 - 24035 Curno - Bergamo
Tel. +39 035 461444 - Fax +39 035 461671
info@losma.it - www.losma.it



ISO 9001
TUV Italia
Certified
Company



ISO 14001
TUV Italia
Certified
Company



Authorised
to use

Losma SpA

Turin office:

Via G. Brunero, 2 - 10077 San Maurizio Canavese - Torino
Tel. +39 011 9278942 - Fax +39 011 9275631
info@losma.it - www.losma.it

Losma GmbH

Siemensstr. 14/3 - 71691 Freiberg am Neckar
Tel. +49 7141 / 89971-0
info@losma.de - www.losma.de

Losma Inc.

30A Wilson Drive - Sparta - NJ 07871
Tel. + 1 973 248 0070 - Fax + 1 973 940 0950
info@losmausa.com - www.losma.com

Losma UK Ltd.

6 Strensham Business Park
WR8 9JZ Strensham Worcestershire
Tel. +44 1684 276527 - Fax +44 1684 276470
info@losma.co.uk - www.losma.co.uk

Losma Pvt Ltd.

Plot No 7A, Gat. No. 63, Shindewadi
Tal: Bhor, District: Pune - 412205 - Maharashtra
Tel. +91 9226107775
info@losma.in - www.losma.com