



Made in Germany



Gauge Blocks and Accessories

**Wear resistant Special Steel
Ceramic
Carbide**



DAkks-Calibration Laboratory
scope of accreditation
according to the current annexe:
www.dakks.de

KOLB & BAUMANN GMBH & CO. KG
PRECISION MEASURING TOOLS MAKERS
DE-63741 ASCHAFFENBURG · DAIMLERSTR. 24
GERMANY
PHONE +49 (6021) 3463-0 · FAX +49 (6021) 3463-40
www.koba.de · messzeuge@koba.de

Catalogue No. 1000/E/01/2012

Dear Customer,

Today you have the documents of KOLB & BAUMANN in your hands.

We are glad that you are interested in our products.

The foundations of KOBA were laid more than 70 years ago and at the beginning the manufacture of gauge blocks was the major line. At that time gauge blocks were made out of steel. Later carbide and ceramic were added. Furthermore we manufacture accessories in order to extend the application of our gauge blocks. In order to complete the product range we started the manufacture of gauges.

It was in 1979 when KOLB & BAUMANN got accredited by the PTB as the 8th DKD-calibration laboratory in Germany. This accreditation comprises the measured value "length" up to 1000 mm. Besides, KOBA is accredited laboratory for gauges and other measuring instruments.

KOBA supplies world-wide into more than 70 countries and is also supplier for gauge blocks and calibration masters to various National Physical Laboratories.

Our world-wide customers trust in KOBA-gauge blocks and gauges as a high-grade German quality product.

Being a German family-based company we will do all efforts to keep the confidence in our products. This is our tradition and obligation for the future.

Your KOBA-management



Dipl.-Bw. Alexander Baumann-Rassokhatskyi

Contents

Gauge Block	Page
Introduction	6
Ceramic Gauge Blocks	7
Accuracy	8
Material	9
Single Gauge Blocks	9
Sets of Gauge Blocks	10 + 11 + 12
Calibration master	
Clamping stand	
Check set for depth gauges	13
Calibration of Gauge Blocks	14 + 15
Maintenance of Gauge Blocks	16
Gauge Block Accessories	
Examples	17
Gauge Block Holders	18
Measuring Jaws	18
Other Accessory Parts	19
Accessory Sets	20
Accessory Sets for internal precision instruments	21
Your Contact Persons	23
Manufacturing programme	24

Subject to modifications of design, dimensions, combinations and weights.

Reprint of text and illustration, also as excerpts, only with our authorization.

The data of the Standard Sheets are given herein by the courtesy of the German Standardization Committee. The latest edition is available in Standard Sheet Size A 4 from Messrs. Beuth-Vertriebs-GmbH, 10787 Berlin.

**HARDNESS
WEAR
RESISTANCE
STABILITY
SERVICE**



Gauge Blocks

are a high quality product: Our exacting standards are backed by more than 70 years experience and research, resulting in the careful selection of the purest steel which must fulfill our high standard demanded, especially with regard to

stability, wear resistance, uniform co-efficient of expansion. The ageing to eliminate internal stresses and stabilizing methods, along with special lapping techniques are some of the many critical considerations KOBA offers to potential users.

All gauge blocks and accessory sets are supplied in wooden storage cases, in ingenious "easy to select" design.

The use of gauge block accessories in conjunction with gauge blocks offers the possibility of many measuring and gauging applications. KOBA accessories are manufactured to the same exacting standard as are our gauge blocks.

When KOBA is selected we are confident that our customers are obtaining the very best in materials, workmanship and, most important, value for money. KOLB & BAUMANN runs a DAKKS laboratory.



Made in Germany

KOBA - Ceramic - Gauge Blocks made of zirconia



wear resistant – stability in size – corrosion resistant



Advantages:

- wear resistant similar to carbide
- high hardness
- thermal expansion coefficient almost similar to steel
- corrosion resistant
- each ceramic gauge block is provided with identification number and calibration certificate
- best for use in the work shop

Technical data:

- density 6,05 g/cm³
- total porosity 0 ‰
- hardness 1350 HV
- compressive strength 2100 N/mm²
- bending strength 800 N/mm²
- modulus of elasticity 205.000 N/mm²
- thermal conductivity 2,3 W/mK
- coefficient of expansion $(10 \pm 1) \cdot 10^{-6} \text{ K}^{-1}$



Limit deviations of the length l_e at any point and tolerances of variation in length l_V to EN ISO 3650:1998, former DIN 861

nominal length range mm	calibration grade K		grade 0		grade 1		grade 2	
	limit deviations of length at any point from nominal length	tolerance for the variation in length	limit deviations of length at any point from nominal length	tolerance for the variation in length	limit deviations of length at any point from nominal length	tolerance for the variation in length	limit deviations of length at any point from nominal length	tolerance for the variation in length
	$\pm l_e$ μm	l_V μm	$\pm l_e$ μm	l_V μm	$\pm l_e$ μm	l_V μm	$\pm l_e$ μm	l_V μm
from 0,5 up to 10	0,2	0,05	0,12	0,1	0,2	0,16	0,45	0,3
over 10 up to 25	0,3	0,05	0,14	0,1	0,3	0,16	0,6	0,3
over 25 up to 50	0,4	0,06	0,2	0,1	0,4	0,18	0,8	0,3
over 50 up to 75	0,5	0,06	0,25	0,12	0,5	0,18	1	0,35
over 75 up to 100	0,6	0,07	0,3	0,12	0,6	0,2	1,2	0,35
over 100 up to 150	0,8	0,08	0,4	0,14	0,8	0,2	1,6	0,4
over 150 up to 200	1	0,09	0,5	0,16	1	0,25	2	0,4
über 200 up to 250	1,2	0,1	0,6	0,16	1,2	0,25	2,4	0,45
over 250 up to 300	1,4	0,1	0,7	0,18	1,4	0,25	2,8	0,5
over 300 up to 400	1,8	0,12	0,9	0,2	1,8	0,3	3,6	0,5
over 400 up to 500	2,2	0,14	1,1	0,25	2,2	0,35	4,4	0,6
over 500 up to 600	2,6	0,16	1,3	0,25	2,6	0,4	5,0	0,7
over 600 up to 700	3	0,18	1,5	0,3	3	0,45	6,0	0,7
over 700 up to 800	3,4	0,2	1,7	0,3	3,4	0,5	6,5	0,8
over 800 up to 900	3,8	0,2	1,9	0,35	3,8	0,5	7,5	0,9
over 900 up to 1000	4,2	0,25	2	0,4	4,2	0,6	8	2

Accuracy

KOBA Gauge Blocks are manufactured and verified to the specifications of EN ISO 3650. As tolerances are kept to a minimum by internal standards, it is guaranteed that every KOBA Gauge Block is within the limits stipulated.



△ KOBA-Laboratory (partial view)

Gauge Block Inspection ▽



The high level of accuracy and the reliability of the measuring results are guaranteed by two separate feed-backs attributed to the internationally fixed unit of length by means of a wave length:

- permanent comparison with the master gauges interferometrically verified by the Physikalisch-Technischen Bundesanstalt,
- parallel to this calibration in our fully airconditioned laboratories.

Tolerance ranges of the individual grades within the limits of which the actual size is guaranteed, can be taken from the table above.

The durability of gauge blocks is achieved by a special process developed by us, combining natural and artificial ageing.

The grade of accuracy should be selected according to the intended purpose.

K: Gauge blocks of Grade K are excellently suitable as the most accurate material measure with regard to length, and for checking gauge blocks of lower grades.

Gauge blocks of Grade K will be clearly marked with a serial No. They will be supplied with a DAKS-calibration certificate which shows the deviation from the nominal size of each gauge block.

- 0: Used as master gauges for all accurate measurements of length, for checking all gauge blocks in use, for final inspection, for setting accurate measuring instruments.
- 1: For checking of gauges, for setting measuring instruments.
- 2: Used as standard for setting or workshop gauge for the manufacture of jigs and gauges, as well as for machines and instruments.

Upon request we supply a calibration certificate of the Physikalisch-Technische Bundesanstalt, which will be charged separately.

In most of the factories the use of only one grade will not do, as the accuracy varies in the individual departments and manufacturing stages. But just this fact implies the efficient use of gauge blocks. Example: If gauge blocks of grade 0 are no longer accurate enough for inspection as a result of frequent use they are passed on to a department or workshop place where the demands on the accuracy are accordingly lower.

We recommend, however, to have them inspected at our laboratory before passing on.

Material

Special Steel stable in size, wear resistant

KOBA Steel Gauge Blocks

This carefully hardened and stress relieved steel type which is specially melted resulting in the highest possible degree of purity has a homogeneous molecular distribution which gives excellent properties against abrasion and wear. The wear is well minimized due to the homogenous dispersal of steel elements and thus uniform fine structure of carbide components. A clever method of ageing will remove residual austenite and therefore guarantee smallest possible changes in size even below the ISO-standard.

Ceramic

KOBA Ceramic Gauge Blocks

The wear behavior of KOBA Ceramic Gauge Blocks is similar to that of carbide. The co-efficient of thermal expansion is closer to steel and is $(10 \pm 1) \cdot 10^{-6} \text{ K}^{-1}$. Ceramic gauge blocks are not subject to corrosion and are therefore excellently suitable for the work shop. The bending strength of 800 N/mm^2 is so high that there is no danger of breakage during ordinary use. KOBA Ceramic Gauge Blocks are available in grades K, 0, 1 and 2.

Carbide

KOBA Carbide Gauge Blocks

The wear ratio as compared to that of steel is approx. 1:50 to 1:100. Carbide gauge blocks are mainly used as wear protectors as gauge block combination specially wears at the outside measuring faces.

All KOBA gauge block sets are provided with two empty slots for storing carbide wear protectors, in 1 mm or 2 mm.

Every gauge block from 0,5 – 100 mm is available of solid tungsten carbide. The material used in these gauge blocks has a co-efficient of thermal expansion $4,5 \cdot 10^{-6} \text{ K}^{-1}$. Carbide gauge blocks are used in workshops and tool rooms under severe wear and abrasion conditions.

We wish to stress that steel gauge blocks be used where work pieces of steel have to be checked and a standard reference temperature of exactly 20°C cannot be maintained. Considering the difference of the co-efficient of thermal expansion between steel and carbide, this would lead to a larger uncertainty of measurement.

Single Gauge Blocks

from – up to	Graduation	Material
0,1 – 0,49	0,01	H
0,5 – 0,99	0,01	SH
0,5 – 0,95	0,05	K
1		SHK
1,0005		SHK
1,001 – 1,009	0,001	SHK
1,01 – 1,49	0,01	SHK
1,5 – 1,9	0,1	SHK
2 – 25	0,5	SHK
30		SHK
40		SHK
50		SHK
60		SHK
70		SHK
75		SHK
80		SHK
90		SHK
100		SHK

S = available in steel

H = available in carbide

K = available in ceramic

nominal size	Material
125	S
150	S
175	S
200	S
250	S
300	S
400	S
500	S
600	S
700	S
800	S
900	S
1000	S

S = available in steel

Intermediate sizes on request

Cross section

Rectangular cross section:

below 0,5 mm $20 \times 9 / 30 \times 9$
0,5 – 10 mm 30×9
over 10 mm 35×9

Gauge Blocks over 100 mm are manufactured with clamping holes at both ends and may also be used with holders of other manufacturers.

Other cross sections on request.

Storage case

KOBA Gauge Blocks are furnished in fine wooden boxes.

Every case is provided with a serial No.



Verification by means of the interference comparator at the KOBA laboratory.



1087 M



1111 M

Gauge Block Sets, metric

Smallest Step mm	Number of Gauge Blocks	Contents dimensions in mm	pcs.	Weight kg	Set No. Order No.
0,0005	122	1,0005 1,001 1,002 1,003 . . . 1,009 1,01 1,02 1,03 . . . 1,49 0,5 1 1,5 1,6 1,7 1,8 1,9 2 2,5 3 . . . 25 30 40 50 60 70 75 80 90 100	1 9 49 7 47 5 4	4,2	1122 M ...4001122
0,001	116	1,001 1,002 1,003 . . . 1,009 1,01 1,02 1,03 . . . 1,49 0,5 1 1,5 2 . . . 25 30 40 50 60 . . . 100	9 49 50 8	4,0	1116 M ...4001116
0,001	111	1,001 1,002 1,003 . . . 1,009 1,01 1,02 1,03 . . . 1,49 0,5 1 1,5 2 . . . 24,5 25 50 75 100	9 49 49 4	3,8	1111 M ...4001111
0,0005	112	Supplement to 1111 M plus size 1,0005 (1111 M + 1,0005 mm)		3,8	1112 M ...4001112
0,005	103	1,005 1,01 1,02 1,03 . . . 1,49 0,5 1 1,5 2 . . . 24,5 25 50 75 100	1 49 49 4	3,8	1103 M ...4001103
0,001	91	1,001 1,002 1,003 . . . 1,009 1,01 1,02 1,03 . . . 1,49 1,6 1,7 1,8 1,9 0,5 1 1,5 2 . . . 9,5 10 20 30 . . . 100	9 49 4 19 10	3,1	1091 M ...4001091
0,001	87	1,001 1,002 1,003 . . . 1,009 1,01 1,02 1,03 . . . 1,49 0,5 1 1,5 2 . . . 9,5 10 20 30 . . . 100	9 49 19 10	3,0	1087 M ...4001087
0,0005	88	Supplement to 1087 M plus size 1,0005 (1087 M + 1,0005 mm)		3,0	1088 M ...4001088
0,005	83	1,005 1,01 1,02 1,03 . . . 1,49 1,6 1,7 1,8 1,9 0,5 1 1,5 2 . . . 9,5 10 20 30 . . . 100	1 49 4 19 10	3,0	1083 M ...4001083
0,005	79	1,005 1,01 1,02 1,03 . . . 1,49 0,5 1 1,5 2 . . . 9,5 10 20 30 . . . 100	1 49 19 10	3,0	1079 M ...4001079
0,005	76	1,005 1,01 1,02 1,03 . . . 1,49 0,5 1 1,5 2 . . . 9,5 10 20 30 40 50 75 100	1 49 19 5 2	2,5	1076 M ...4001076
0,005	47	1,005 1,01 1,02 1,03 . . . 1,09 1,1 1,2 1,3 . . . 1,9 1 2 3 . . . 24 25 50 75 100	1 9 9 24 4	2,6	1047 Ma ...4011047
0,005	47	1,005 1,01 1,02 1,03 . . . 1,19 1,2 1,3 1,4 . . . 1,9 1 2 3 . . . 9 10 20 30 . . . 100	1 19 8 9 10	2,6	1047 Mb ...4021047



The first three number of the Order No. compose as follows:

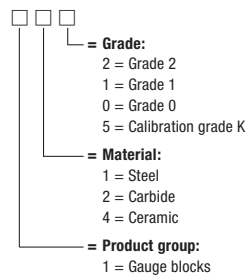

Next is the seven digit order code.

Example:
 Gauge block set 103 pcs; Set No. 1103 M;
 Material: steel; Grade 0 = Order No. 110 4001103



Made in Germany

- Each Gauge Block set (except for the supplementary sets) are provided with additional slots for storage of 2 carbide wear protectors 1 mm or 2 mm.
- The insert of the storage case is screwed and can be removed for cleaning.
- Bottom and cover of the storage cases contain a layer of special paper for rust prevention.



1047 Ma



1008 M

Gauge Block Sets, metric



The first three number of the Order No. compose as follows:

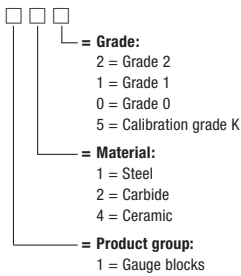

Next is the seven digit order code.

Example:

Gauge block set 32 pcs; Set No. 1032 M;

Material: steel; Grade 2 = Order No. 112 4001032



Made in Germany

Smallest Step mm	Number of Gauge Blocks	Contents dimensions in mm	pcs.	Weight kg	Set No. Order No.
0,001	46	1,001 1,002 1,003 . . . 1,009 1,01 1,02 1,03 . . . 1,09 1,1 1,2 1,3 . . . 1,9 1 2 3 . . . 9 10 20 30 . . . 100	9 9 9 9 10	2,6	1046 M ...4001046
0,001	41	1,001 1,002 1,003 . . . 1,009 1,01 1,02 1,03 . . . 1,09 1,1 1,2 1,3 . . . 1,9 1 2 3 . . . 9 10 20 40 70 100	9 9 9 9 5	2,0	1041 M ...4001041
0,005	38	1,005 1,01 1,02 1,03 . . . 1,09 1,1 1,2 1,3 . . . 1,9 1 2 3 . . . 9 10 20 30 . . . 100	1 9 9 9 10	2,5	1038 M ...4001038
0,005	33	1,005 1,01 1,02 1,03 . . . 1,09 1,1 1,2 1,3 . . . 1,9 1 2 3 . . . 9 10 20 40 70 100	1 9 9 9 5	1,6	1033 M ...4001033
0,005	32	1,005 1,01 1,02 1,03 . . . 1,09 1,1 1,2 1,3 . . . 1,9 1 2 3 . . . 9 10 20 30 50	1 9 9 9 4	1,2	1032 M ...4001032
0,005	18	1,005 1,01 1,02 1,03 1,06 1,1 1,2 1,3 1,6 1 2 3 6 10 20 30 60 100	1 4 4 4 5	1,5	1018 Ma ...4011018
0,001	18	1,001 1,002 . . . 1,009 1,01 1,02 . . . 1,09	9 9	0,4	1018 Mb ...4021018
0,001	9	1,001 1,002 . . . 1,009	9	0,25	1009 Ma ...4011009

Gauge Block Set for the calibration of gauge block comparators as per guideline DAkkS-DKD-R 4-1 - 2nd New Edition 2010

-	11	0,5 0,5 1,0 1,005 1,01	6	1,0	1011 M
-		4,0 4,0 100 100 (bridge type)	6		1154001011

Uncertainties of measurement: PTB: U = 0,01 µm / KOBA: U = 0,03 µm

Gauge Block Sets over 100 mm

-	8	125 150 175 200 250 300 400 500	4 1 3	7	1008 M ...4001008
100	9	200 300 400 500 600 700 800 900 1000	5 4	18	1009 Mb ...4021009
100	5	600 700 800 900 1000	5	10	1005 M ...4001005
-	6	50 100 200 300 400 500	6	5	1006 M ...4001006

- Each Gauge Block set (except for the supplementary sets) are provided with additional slots for storage of 2 carbide wear protectors 1 mm or 2 mm.
- The insert of the storage case is screwed and can be removed for cleaning.
- Bottom and cover of the storage cases contain a layer of special paper for rust prevention.



1010 MP

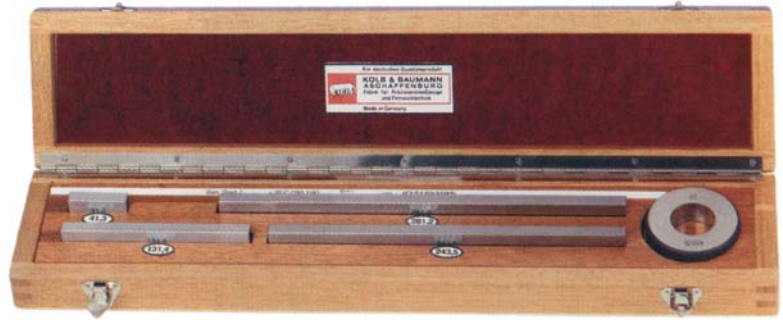

1004 MR

Gauge Block Sets for the inspection of measuring tools (DIN/ISO 9000ff)

Smallest Step mm	Number of Gauge Blocks	Contents dimensions in mm	Weight kg	Set No. Order No.
Check sets for micrometer calipers (see page 12 for clamping stand)				
-	10	for 0–25 2,5 5,1 7,7 10,3 12,9 15 17,6 20,2 22,8 25	1,0	1010 M ...4001010
-	10	2,5 5,1 7,7 10,3 12,9 15 17,6 20,2 22,8 25 plus 1 optical parallel Ø 30 mm	1,2	1010 MP ...4301010
-	11	for 25–50 25 27,5 30,1 32,7 35,3 37,9 40 42,6 45,2 47,8 50	1,8	1011 Ma* ...4011011
-	11	for 50–75 50 52,5 55,1 57,7 60,3 62,9 65 67,6 70,2 72,8 75	2,6	1011 Mb* ...4021011
-	11	for 75–100 75 77,5 80,1 82,7 85,3 87,9 90 92,6 95,2 97,8 100	3,5	1011 Mc* ...4031011
-	13	for 0–100 Supplement to 1010 M plus sizes 50 75 100	1,5	1013 M ...4001013
Check sets for vernier calipers				
-	2	for 0–150 41,3 131,4	1,0	1002 M ...4001002
-	2	for 0–150 41,3 131,4 plus 1 ring gauge Ø 30 mm	1,1	1002 MR ...4201002
-	3	for 0–200 and 0–250 41,3 131,4 243,5	1,5	1003 M ...4001003
-	4	for 0–200, 0–250 and 0–300 41,3 131,4 243,5 281,2	2,3	1004 M ...4001004
-	4	for 0–200, 0–250 and 0–300 41,3 131,4 243,5 281,2 zusätzlich 1 Ring Ø 30	2,5	1004 MR ...4201004
-	5	for 0–500 41,3 131,4 243,5 281,2 481,1	4,0	1005 Mb ...4021005
-	7	for 0–1000 41,3 131,4 243,5 281,2 481,1 700 900	9,0	1007 M ...4001007
The gauge blocks mentioned are also available individually or as sets with different compositions. The nominal sizes stated are in accordance with guideline VDI/VDE/DGQ 2618.				
Combination set for micrometer calipers 0–25 and vernier calipers 0–150				
-	12	for 0–25 2,5 5,1 7,7 10,3 12,9 15 17,6 20,2 22,8 25 for 0–150 41,3 131,4 plus 1 optical parallel Ø 30 and 1 ring gauge Ø 30 mm	2,0	1012 MPR ...4401012
-	12	same as 1012 MPR but without optical parallel and ring gauge	1,8	1012 M ...4001012



Made in Germany

* available Grade 1 and 2 only

- The insert of the storage case is screwed and can be removed for cleaning.
- Bottom and cover of the storage cases contain a layer of special paper for rust prevention.

Calibration master for checking vernier calipers and height gauges

Gauge blocks in ceramic

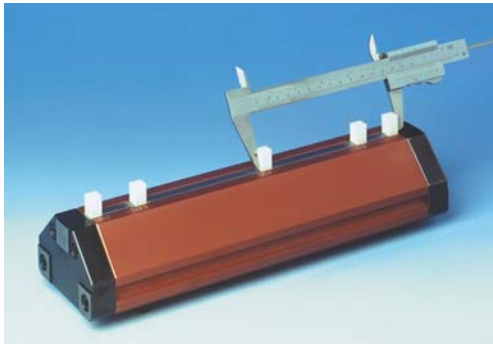

For measuring range up to 300 mm.

Steps according to VDI/VDE/DGQ 2618
41,3/131,4/243,5/281,2 mm.

For horizontal and vertical application.

Set No. 1004 Ma (5,2 kg/with box 9,3 kg)
Order No. 5410011004

For measuring range up to 500 mm.

Steps according to VDI/VDE/DGQ 2618
41,3/131,4/243,5/281,2/481,1 mm.

For horizontal and vertical application.

Set No. 1005 Ma (7,6 kg/with box 10,9 kg)
Order No. 5410011005

For measuring range up to 1000 mm.

Steps according to VDI/VDE/DGQ 2618
41,3/131,4/243,5/281,2/481,1/700/900 mm.

For horizontal and vertical application.

Set No. 1007 Ma (12,8 kg/with box 20,5 kg)
Order No. 5410011007

Other spacings available on request.



Clamping stand No. 2350



Measuring range 0–100 mm,

in combination with check sets 1010 M /
1010 MP / 1011 Ma / 1011 Mb / 1011 Mc.

Simple and efficient handling while
temperature of the hand will be avoided.

Set No. 2350
Order No. 2160002350



Made in Germany

Check set for depth gauges



Composition same as Set No. 1010 M
Set No. 1010 MT / Order No. 5324401010

Composition same as Set No. 1011 Ma
Set No. 1011 MaT / Order No. 5324411011

Composition same as Set No. 1011 Mb
Set No. 1011 MbT / Order No. 5324421011

Composition same as Set No. 1011 Mc
Set No. 1011 McT / Order No. 5324431011

Other steps on request.





Calibration of Gauge Blocks

DAkKS Calibration

Reliability through accreditation by DAkKS

Requirements regarding the quality of goods and services are continuously increasing as a result of the liberalisation of global trade and increasing demands by consumers, companies and legislators. Objective calibrations therefore play a very important role. In order to meet these requirements, Kolb & Baumann GmbH & Co. KG set up a calibration laboratory by the Deutscher Kalibrierdienst (DKD) back in 1979 which has later been accredited to DIN EN ISO/IEC 17025.

As from 17 December 2009 the accreditation body of the Deutscher Kalibrierdienst (DKD) was taken over by the Deutsche Akkreditierungsstelle GmbH (DAkKS) and since 29 March 2011 the KOBAs calibration laboratory continues as a DAkKS-laboratory having the Laboratory N° D-K-15077-01-00.

Calibration of Gauge Blocks according to guideline DAkKS-DKD-R 4-3:

Scopes of calibration:

Option 5.3.1: Full calibration





Visual control – wringing of both measuring surfaces – Determination of the deviation of the central size from the nominal size, as well as f_o and f_u – minimum 5 measuring cycles

Option 5.3.2: Reduced calibration

Visual control – Inspection of flatness of both measuring surfaces – Determination of the deviation of the central size from the nominal size, as well as f_o and f_u – minimum 3 measuring cycles

Option 5.3.3: Minimal calibration

Visual control – Determination of the deviation of the central size from the nominal size, as well as f_o and f_u – minimum 3 measuring cycles

		KOLB + BAUMANN PRÄZISIONS-MESSZEUGE
<small>Kolb & Baumann GmbH & Co. KG - Fabrik für Präzisions-Messzeuge Daimlerstraße 24 · D-63741 Aschaffenburg · Germany</small>		
akkreditiert durch die / accredited by the		
Deutsche Akkreditierungsstelle GmbH		
als Kalibrierlaboratorium im / as calibration laboratory in the		
Deutschen Kalibrierdienst		DKD
Kalibrierschein Calibration certificate		30000 D-K-15077-01-00 2012-03
Gegenstand Object	122 gauge blocks according to DIN EN ISO 3650 out of steel, from nominal size 0,50 up to 100 mm inclusive	Dieser Kalibrierschein dokumentiert die Rückführung auf nationale Normale zur Darstellung der Einheiten in Übereinstimmung mit dem Internationalen Einheitensystem (SI). Die DAkKS ist Unterzeichner der multilateralen Übereinkommen der European co-operation for Accreditation (EA) und der International Laboratory Accreditation Cooperation (ILAC) zur gegenseitigen Anerkennung der Kalibrierscheine. Für die Einhaltung einer angemessenen Frist zur Wiederholung der Kalibrierung ist der Benutzer verantwortlich. This calibration certificate documents the traceability to national standards, which realize the units of measurement according to the International System of Units (SI). The DAkKS is signatory to the multilateral agreements of the European co-operation for Accreditation (EA) and of the International Laboratory Accreditation Cooperation (ILAC) for the mutual recognition of calibration certificates. The user is obliged to have the object recalibrated at appropriate intervals.
Hersteller Manufacturer	"KOBAs" Kolb & Baumann	
Typ Type		
Fabrikat/Serien-Nr. Serial number	80000	
Auftraggeber Customer	Mustermann GmbH Musterstraße 123 98765 Musterstadt	
Auftragsnummer Order No.	12345	
Anzahl der Seiten des Kalibrierscheines Number of pages of the certificate	6	
Datum der Kalibrierung Date of calibration	27.03.2012	
<small>Dieser Kalibrierschein darf nur vollständig und unverändert weiterverbreitet werden. Auszüge oder Änderungen bedürfen der Genehmigung sowohl der Deutschen Akkreditierungsstelle GmbH als auch des ausstellenden Kalibrierlaboratoriums. Kalibrierscheine ohne Unterschrift haben keine Gültigkeit. This calibration certificate may not be reproduced other than in full except with the permission of both the Deutsche Akkreditierungsstelle GmbH and the issuing laboratory. Calibration certificates without signature are not valid.</small>		
Datum Date	Leiter des Kalibrierlaboratoriums Head of the calibration laboratory	Sachbearbeiter Person in charge
		
27.03.2012	Dipl. Ing. (FH) Martin Wombacher	K. Rauner

A statement as to whether sent-in gauge blocks are suitable for calibration can be made only during the calibration procedure. If you failed to specify the option according to the field of application we will carry through a calibration with the smallest possible uncertainty of measurement depending on the state of the gauge blocks. A subsequent modification is not possible.

In case of any deviation from your calibration request we shall contact you the soonest possible in order to avoid unnecessary costs.



Calibration of Gauge Blocks

Manufacturer's calibration within the framework of the KOBA Calibration Service (KKS)

Gauge blocks are an important connecting link for the traceability to National Standards of the length measuring practice. In order to meet the requirements of DIN/ISO 9000 it is imperative to know their actual condition and to control them constantly.

This is where the KOBA Calibration Service can support you.

Since the rate of wear on individual gauge blocks differs, depending on how much use is made of them and what they are used for, it is not possible to lay down any standard interval between checks.

However, an one year interval has proved satisfactory in practice.

Calibration sequence

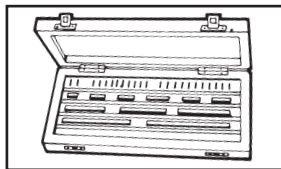

You are sending a gauge block set for re-calibration.

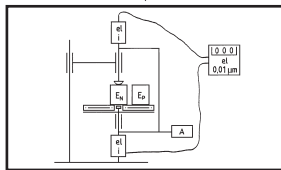

Gauge blocks are cleaned, de-magnetized, measuring faces are smoothed and then checked against DAkkS-calibrated masters by five-points-measurement.

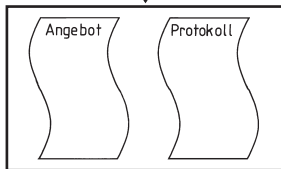

An inspection certificate with the actual findings is drawn up and sent to you together with an offer for the replacement of worn gauge blocks.



You decide, to which grade we shall replace.

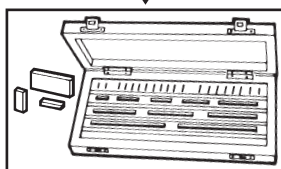

We will return the set inspected and partly replaced together with a new inspection certificate including the findings of the replaced gauge blocks and separately all the worn gauge blocks which still can be used for less important jobs.

Advantages

- The entire set is of only one grade of accuracy
- Smallest possible number of replacements
- Costs are low
- Assured standards for your quality control

When buying gauge blocks do not forget the calibration service. Without it cheap blocks may end up costing you a lot of money.

KOBA-Kalibrier-Service
Kalibrierlaboratorium für die Messgröße Länge
KOBA-Calibration-Service / Service de Contrôle KOBA

KOLB + BAUMANN
PRÄZISIONS-MESSZÜGE

page 2 of calibration certificate No. Specimen 1 vom 26.03.12

Nominal Size in mm	Centre Deviation in µm	Variation Range fo fu in µm	Accuracy	Serial No.
0.50				
1.0				
1.001				
1.002				
1.003				
1.004				
1.005				
1.006				
1.007				
1.008				
1.009				
1.01				
1.02				
1.03				
1.04				
1.05				
1.06				
1.07				
1.08				
1.09				
1.10				
1.11				
1.12				
1.13				
1.14				
1.15				
1.16				
1.17				
1.18				
1.19				
1.20				
1.21				
1.22				
1.23				
1.24				
1.25				
1.26				
1.27				
1.28				
1.29				
1.30				

KOBA-Kalibrier-Service
Kalibrierlaboratorium für die Messgröße Länge
KOBA-Calibration-Service / Service de Contrôle KOBA

KOLB + BAUMANN
PRÄZISIONS-MESSZÜGE

Calibration certificate No.: Specimen 1

Client: Specimen
Specimenstreet 123
1234 Spicity

Client-No.: 00000
Client Order No.: 000000
Works Order No.: Specimen 1

Object of calibration: Gauge Block Set, made of steel
87-pcs., Tolerance Class 0

Size: 0,50 mm - 100 mm
Manufacturer's logo: KOBA
Identification-No.: 12345
Coefficient of thermal expansion: $\alpha = 11,9 \times 10^{-6} \text{ K}^{-1}$

Test procedure: Measuring of the centre deviation and the variation range by comparison against gauge blocks in accordance with DIN EN ISO 3650

Measurement standard: Measuring equipment: TESA UPC, Serial-No.: 4563
Gauge block set, Serial-No. 87895
DAkkS-certificate 0130 D-K-15077-01-00 2011-06

Uncertainty: $U = 0,10 \mu\text{m} + 1 \times 10^{-6} \times L$; with $k = 2$

Result: Statement of the actual sizes

Number of pages: 4

Aschaffenburg, 26.03.12

Inspected by: Ganster

KoB & Baumann GmbH & Co. KG
Hersteller von Präzisions-Messzügen

Daimlerstraße 24
63741 Aschaffenburg

Telefon (0927) 3463-0
Telefax (0927) 3463-40

www.koba.de
messzuege@koba.de

The calibration procedure

1. The gauge blocks are cleaned and de-magnetized.
2. Scratches and burrs are removed from the gauge faces and edges. The gauge faces are dressed smooth.
3. The gauge blocks are checked by measurement by comparison against gauge blocks calibrated by DAkkS (five-points-measurement).
4. A KOBA inspection certificate is drawn up, or in other words a record of the results of the measurements is produced.

If desired the measured results can be shown in detail. For this you can select one of three different types of procedures:

- P2: Grade of accuracy, centre deviation.
- P3: Grade of accuracy, centre deviation (as in P2), and variation range.
- P4: Grade of accuracy, centre deviation (as in P2), variation range (as in P3), additionally wringing of both measuring faces to an optical flat to prove wringability. Blue spots are allowed and acceptable.

Once the calibration has been completed, you will receive from us a KOBA inspection certificate of the kind you opt for together with a quotation for the replacement of gauge blocks which are not suitable for continued use.

Everything from one source. Fast, competent, straight from one supplier.

Servicing Kit

No. 1901 (0,75 kg) Order No. 2070011902



Contents:

- 1 Cloth
- 1 Chamois Leather
- 1 bottle Special Protective Oil
- 1 Deburring Stone no. 1903-1
- 1 Soft Brush
- 1 Grease Brush
- 1 set Instructions

Deburring Stone

No. 1903-1 Ord.No. 2070011903
Size 50 x 25 x 10 mm (0,05 kg)

No. 1903-2 Ord.No. 2070021903
Size 100 x 25 x 10 mm (0,1 kg)



Smallest burrs and scratches on the measuring surfaces can be remedied with the deburring stone without altering the actual size.

Optical Flats

Optical flat, No. 1904-1 (0,16 kg)
Order No. 5770011904



for checking the flatness of measuring faces
45 mm diameter
11 mm thick
0,1 µm flatness accuracy

Optical parallels, in a set No. 1904-2

Order No. 5774021904

for checking parallelism of the measuring faces on micrometer calipers – 4 parallels of thickness:

12,000 / 12,120 / 12,250 / 12,370 mm – diameter 30 mm –
flatness < 0,15 µm – parallelism ≤ 0,3 µm –
thickness tolerance ± 0,1 mm

Optical parallel, No. 1904-3

Order No. 5771031904

thickness 12,000 mm – diameter 30 mm –
flatness < 0,15 µm – parallelism ≤ 0,3 µm –
thickness tolerance ± 0,1 mm

Other sizes upon enquiry.

Special Protective Oil

No. 1902 (0,06 kg) Art.-Nr.
2070021902



50 ccm



Made in Germany

Gauge Block Clamps

for gauge blocks
over 100 mm

No. 1908 (0,2 kg)

Order No.
2060001908



Universal Gauge Block Holder

for individual gauge block
combination over 100 mm

No. 1909

Order No.	clamping range
2110011909	0–45
2110021909	45–90
2110031909	90–135
2110041909	135–180
2110051909	180–225



Gripping Plier

No. 1907 (0,18 kg)
Order No. 2060001907

insulating against heat transfer of the hand and for convenient and easy handling of gauge blocks from 0.5 mm onwards.

The gripping force can be adjusted to take into account the greater weight of the large gauge blocks.



Insulating Handles for Long Gauge Blocks

No. 1905 Order No. 2060001905
(0,15 kg)



No. 1906 (0,1 kg)
Order No. 2060001906



Gauge Block Accessories

are especially designed and manufactured to extend the high degree of gauge block accuracy into the field of fast, accurated temporary gauging, which are used in inspection departments and also in toolroom and machine shops on small batch production to keep gauging costs at a minimum.

The range of possibilities is manifold and below are quoted a number of popular examples.

Internal cylindrical gauge

(instead of plug gauge or cylindrical limit plug gauge)

Spacing or external gauge

(instead of snap gauge or adjustable limit snap gauge)

Precision height gauge (instead of height marking instrument)

Precision marking compasses

Setting gauge for bore gauging instruments

Master gauges for exact graduations, etc.



Examples of Gauge Block Accessories used in conjunction with Gauge Blocks

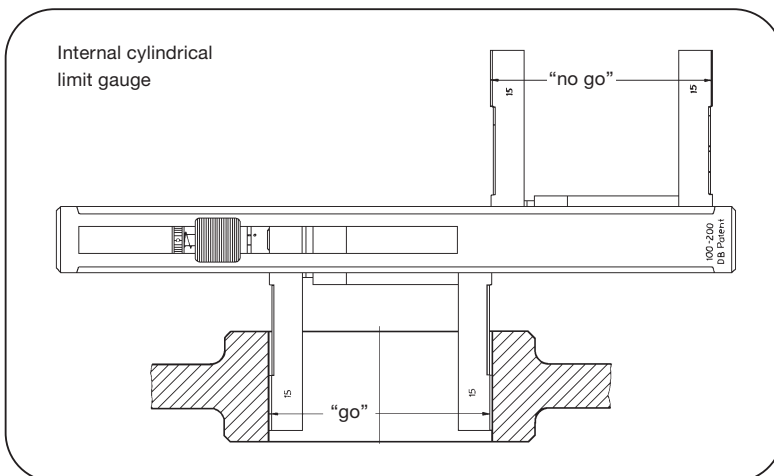
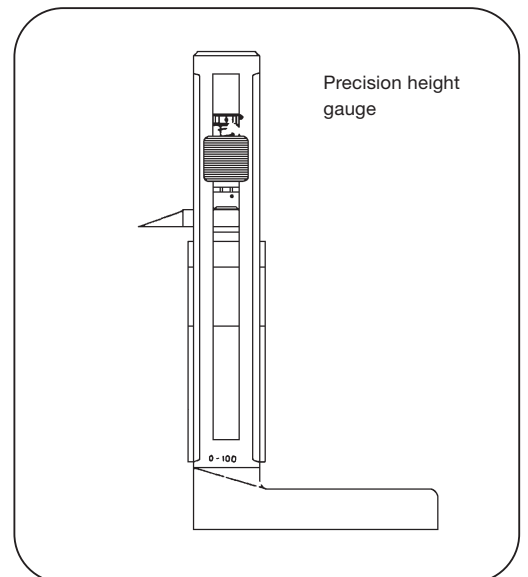
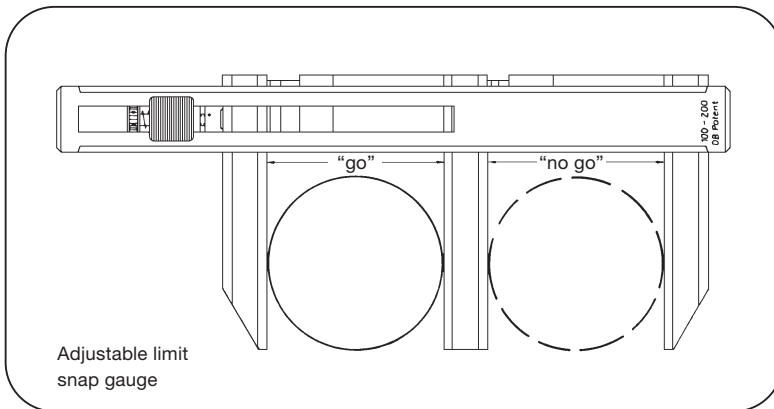
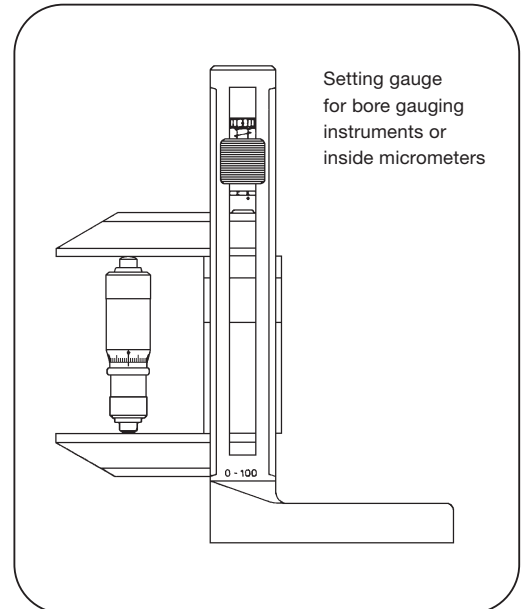
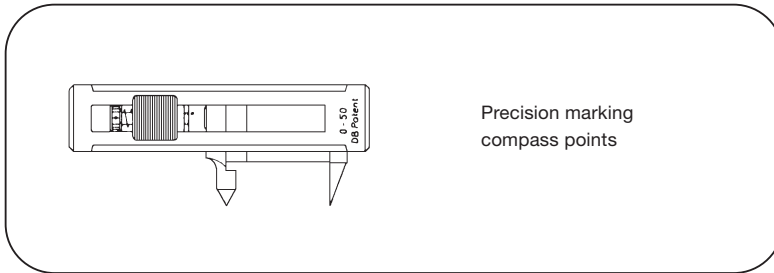

Gauge Block Holders with quick adjustment



KOBA developed quick adjusting gauge block holders for use with precision gauge blocks, which are hand made to assure burr free side and fixing surfaces. The rack pattern positive locating groovers provide rapid adjustment and prevent gauge block combination from slipping or moving once in position, thus loading is simple, fast and safe.

The clamping slide and gauge block combination are both secured by the same thumb screw, located on the clamping slide.

On request the range of holders from 100–300 may be increased when supplied with special holes and used in conjunction with expanding block No. 2150 from 0 up. When ordering please state requirements, e.g. 0–500 mm.

Cat. No.	Measuring range mm	Weight kg
2101	0– 50	0,2
2102	0– 100	0,3
2103	0– 200	0,4
2105	100– 200	0,4
2106	100– 300	0,5
2104	0– 300	0,5
2116	200– 400	0,6
2109	300– 500	0,7
2117	400– 600	0,8
2112	500– 800	1,0
2113	800–1000	1,2
2114	1000–1200	1,4
2115	1300–1500	1,6
2118	1800–2000	1,8



The Order No. for these products consists of:
A 6 digit basic number 211000 and next to it is the 4 digit Cat. No.
Example: Gauge block holder 0–100 mm = 2110002102

Clamping elements for long gauge blocks with pin holes see page 17.

Measuring Jaws

with cylindrical shoulder for inside and outside measurements



Made in Germany

Nominal sizes (dia. of shoulder of 1 pair of jaws)	Maximum gauge depth mm	Cat. No.	Weight kg ea. pair
4 mm	8	2204	0,03
10 mm	15	2210	0,05
16 mm	20	2216	0,07
20 mm	40	2220	0,10
30 mm	65	2230	0,20
40 mm	95	2240	0,35

The Order No. for these products consists of:
A 6 digit basic number 212000 and next to it is the 4 digit Cat. No.
Example: Measuring jaws 20 mm = 2120002220

The permissible deviation of the nominal diameter is equal to the double of the permissible center deviation of a gauge block of the same nominal size in Grade 2.



Control Points



Weight ea.
pair: 0.05 kg

Cat. No. 2330 / Order No. 2130002330
For checking of graduations and of exact distances between points and lines.

Scriber Point



Cat. No. 2322 / Order No. 2130002322
For forming an accurate height gauge: scriber point, gauge block holder, base, gauge blocks.

Centre Point



Weight: 0.03 kg

Cat. No. 2321 / Order No. 2130002322
For forming marking compasses: centre point, scriber point, gauge block holder, gauge blocks.

Plane Jaws



for outside measurements only

Cat. No.	Height abt. mm	Width mm	Length mm	Weight each pair kg
2301	20	9	100	0,18
2302	20	9	125	0,23

Suitable for forming snap gauges or adjustable limit snap gauges

Plane Parallel Jaws



for inside and outside measurements
(not for internal diameter)

Cat. No.	Height (Grade 2) mm	Width mm	Length mm	Weight each pair kg
2304	20	9	100	0,20
2305	20	9	125	0,24

Knife Edge Jaws

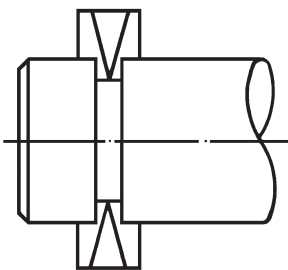

Cat. No.	Max. measurable diameter mm	Length overall mm	Weight each pair abt. kg
2310	26	55	0,07

The Order No. for these products consists of:
A 6 digit basic number 212000 and next to it is the
4 digit Cat. No.

Example: Plane jaws 100 mm = 2120002301



Base

Cat. No. 2340 Order No. 2160002340 Weight: 0,92 kg

The base is used in conjunction with gauge block holders 2101–2113.
The desired size combination is built into the gauge block holder and
the holder is secured vertically on the base by a holding screw.

Accessory Sets for Gauge Blocks



Not illustrated

Set No. 2004 M		mm	Cat. No.
1 pair	of measuring jaws	in all 40	2240
1	Gauge block holder	0-300	2104
1	Gauge block holder	300-500	2109
Weight incl. case abt. 2,5 kg		Ord. No. 2150002004	



Set No. 2010 M

Set No. 2010 M		mm	Cat. No.
1 pair	of measuring jaws	in all 4	2204
1 pair	of measuring jaws	in all 10	2210
1	scriber point	-	2322
1	centre point	-	2321
1	base	-	2340
1	Gauge block holder	0- 50	2101
1	Gauge block holder	0-100	2102
1	Gauge block holder	100-200	2105
Weight incl. case abt. 3 kg		Ord. No. 2150002010	

Not illustrated



Made in Germany

Set No. 2014 M		mm	Cat. No.
1 pair	of measuring jaws	in all 4	2204
1 pair	of measuring jaws	in all 10	2210
1 pair	of measuring jaws	in all 16	2216
1 pair	of measuring jaws	in all 20	2220
1	scriber point	-	2322
1	centre point	-	2321
1	base	-	2340
1	Gauge block holder	0- 50	2101
1	Gauge block holder	0-100	2102
1	Gauge block holder	100-200	2105
Weight incl. case abt. 3,2 kg		Ord. No. 2150002014	



Set No. 2023 M

Set No. 2023 M		mm	Cat. No.
1 pair	of measuring jaws	in all 4	2204
1 pair	of measuring jaws	in all 10	2210
1 pair	of measuring jaws	in all 16	2216
1 pair	of measuring jaws	in all 20	2220
1 pair	of measuring jaws	in all 30	2230
1 pair	of measuring jaws	in all 40	2240
1 pair	of plain parallel jaws	100	2304
1 pair	of knife edge jaws	26	2310
1	scriber point	-	2322
1	centre point	-	2321
1	base	-	2340
1	Gauge block holder	0- 50	2101
1	Gauge block holder	0-100	2102
1	Gauge block holder	100-200	2105
1	Gauge block holder	200-400	2116
Weight incl. case abt. 5 kg		Ord. No. 2150002023	

Accessory Sets for setting Internal Precision Instruments

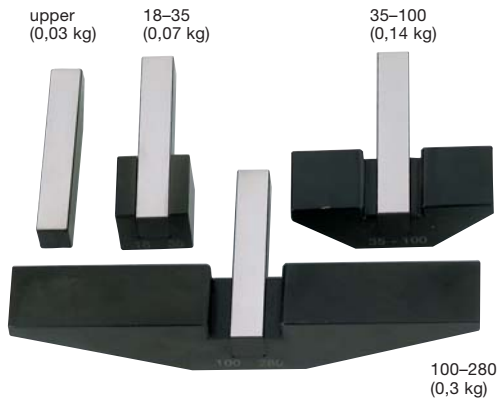

Designation	Measuring Range	Cat. No. Ord. No.
upper measuring jaws	all	2521 2120002521
lower measuring jaws	18- 35	2522 2120002522
lower measuring jaws	35-100	2523 2120002523
lower measuring jaws	100-280	2524 2120002524
lower measuring jaws *	280-510	2525 2120002525

* not illustrated

Set No. Ord. No.	Contents	Measuring Range
2505-1 2150012505	1 upper measuring jaw 1 lower measuring jaw 18- 35 1 lower measuring jaw 35-100 1 Gauge block holder 0-100 1 base	up to 100 mm
2510 2150002510	2 upper measuring jaw 1 lower measuring jaw 18- 35 1 lower measuring jaw 35-100 1 lower measuring jaw 100-280 1 Gauge block holder 0- 50 1 Gauge block holder 0-100 1 Gauge block holder 100-200 1 Gauge block holder 100-300 1 base	up to 280 mm
2505-2 2150022505 not illustrated	1 upper measuring jaw 1 lower measuring jaw 100-280 1 lower measuring jaw 280-510 1 Gauge block holder 100-600 1 base	100 up to 510

2505-1 (2,1 kg)



2510 (4,3 kg)



Parts may be ordered at random leaving open spaces in storage cases if desired.

Notes:



Your Contact Persons at KOBA

Dipl.-Ing. **Martin Wombacher**
Technical Direction, Quality Assurance
Your partner for: QA, EDP, R&D
as well as technical consultation
Tel.: +49 6021 3463-21
Languages: German, English
martin.wombacher@koba.de



Jutta Remmel

Sales
Your partner for: Quotations and handling of orders on gauge blocks and their calibration within the framework of DAkkS and KKS as well as precision parts to customer's requirements
Tel.: +49 6021 3463-13
Languages: German, English
jutta.remmel@koba.de



Robert Schuler

Sales, Head of Purchase
Your partner for: procurement of production material, sale of calibration standards for coordinate measuring machines and their calibration
Tel.: +49 6021 3463-15
Languages: German, English
robert.schuler@koba.de



Dipl.-Bw. **Bruno Bohlender**

Head of Sales and Export
Your partner for: Gauges and calibration of measuring instruments within the framework of DAkkS and KKS
Tel.: +49 6021 3463-14
Languages: German, English, French
bruno.bohlender@koba.de



Jenny Dahedl

Sales
Your partner for: Quotations and handling of orders on cylindrical gauges as well as thread gauges and special gauges
Tel.: +49 6021 3463-18
Languages: German, English
jenny.dahedl@koba.de



Rosemarie Schmah

Sales
Your partner for: Order-confirmation and invoicing, customs handling
Tel.: +49 6021 3463-12
Languages: German, English
rosemarie.schmah@koba.de

Excerpts from our delivery programme:

Angle Gauges

Flat Gauges according to works standard specifications and client's drawing

Master setting pieces

Thread Gauges

Spline Gauges

Plug Gauges

Ring Gauges

Snap Gauges

Step Gauge KOBA-step, patent

Sphere Plate KOBA-check

Ball Bar up to 8 m

Ball Cube KOBA-Q3

Optical scale KOBA-optima

Opto-tactile standards

and our services:

KOBA-calibration service for gauge blocks and gauges

DAkKS-calibration as per accreditations

All orders received are subject to our terms of delivery and sale which are kept at your disposal

How to find our factory

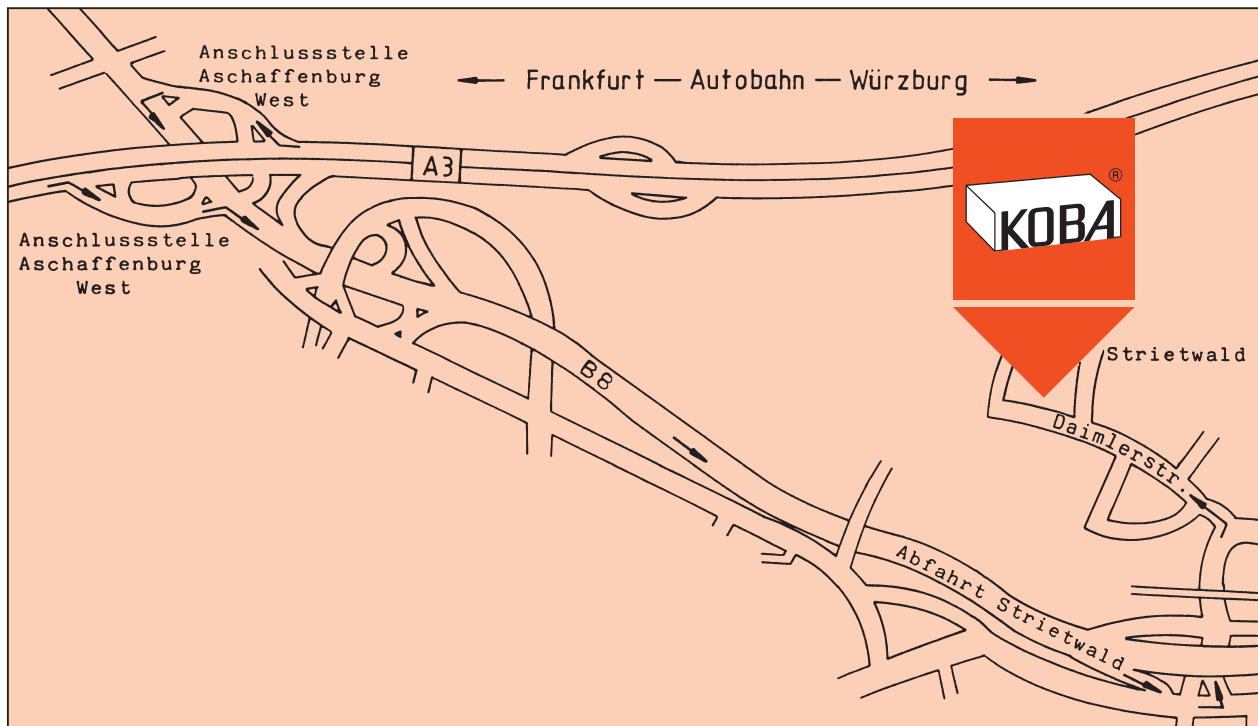

KOLB & BAUMANN GMBH & CO. KG
PRECISION MEASURING TOOLS MAKERS
DE-63741 ASCHAFFENBURG · DAIMLERSTR. 24
GERMANY

PHONE +49 (6021) 3463-0 · FAX +49 (6021) 3463-40
www.koba.de · messzeuge@koba.de

