

Electromagnetic Stationary Field Multi-Disc Clutch

Clutch with outer driver for torque transmission between shaft and free wheeling gear part.

For dry operation, coil voltage 24 V DC

- ◆ Clutch with adjustable air gap.
- ◆ Suited for operating sequences with precise torque control.
- ◆ High energy absorption by wear resistant steel- / sinter discs.
- ◆ Effective heat dissipation by peripheral friction faces.
- ◆ For lowest idling torque non-magnetic discs can be provided.
- ◆ Vertical mounting, only when ordered with application guidelines.

This clutch is specially suited for external gearbox installation.

In main drives for operation of power driven units, for example pumps compressors, and other machinery.

In positioning drives for the control of feed motions.

The accurate engagement response of the clutch with thereby given exact operational control remains unchanged for a longtime period.

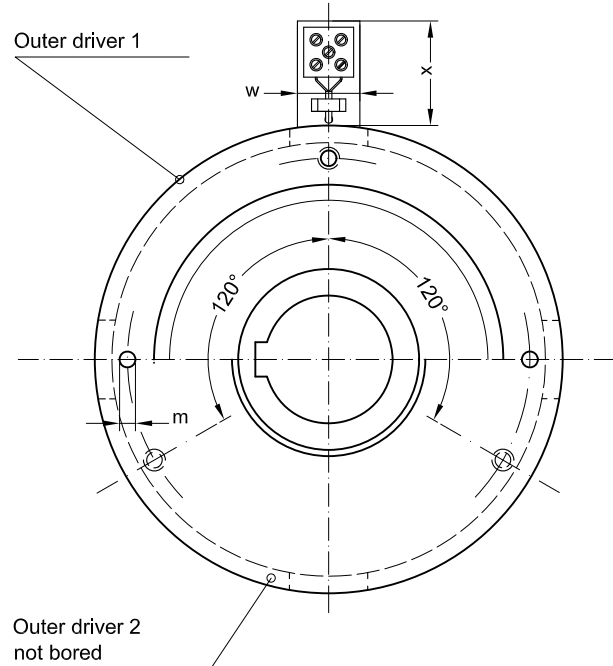
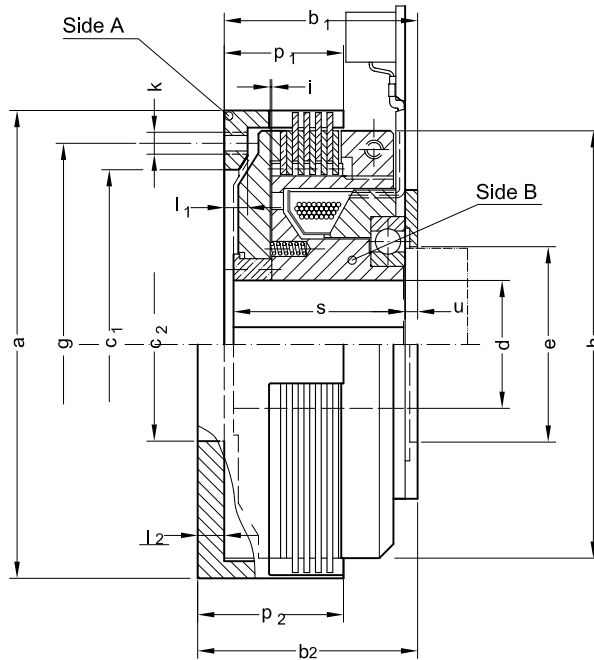

Data and Dimensions		FMV 1,2	FMV 2,5	FMV 5	FMV 10	FMV 20	FMV 40	FMV 80	FMV 160	FMV 315	FMV 630
Static torque	Nm	20	40	80	160	320	630	1250	2500	5000	10000
Dynamic torque	Nm	12	25	50	100	200	400	800	1600	3200	6300
Idling torque	Nm	0,04	0,06	0,1	0,2	0,4	0,6	1,0	1,6	2,4	3,6
Friction work per engagement	kJ	2,4	4,8	10	12,5	20	40	63	120	150	250
Thermal capacity	W	40	54	80	110	135	220	270	410	490	790
Speed maximum	min ⁻¹	4000	3850	3650	3500	3200	2900	2400	1900	1400	1000
Torque-time constant ¹⁾	s	0,15	0,18	0,20	0,25	0,30	0,40	0,50	0,75	1,30	2,00
Disengagement time ²⁾	s	0,05	0,06	0,07	0,08	0,09	0,10	0,15	0,20	0,25	0,30
Coil power consumption at 20 °C	W	15	22	25	35	35	60	75	105	105	105
Mass moment of inertia side A	10 ⁻³ kgm ²	0,4	0,7	1,4	3,3	7,0	17	42	130	288	780
Mass moment of inertia side B	10 ⁻³ kgm ²	0,5	1,1	2,2	5,5	13	34	90	228	713	2375
Mass (weight)	kg	1,6	2	3	4	8	14	23	43	75	140
Ø a	mm	90	99	115	136	161	200	237	292	357	452
b ₁	mm	44,5	46,5	52,5	56	66	78	91,5	102,5	127	152
b ₂	mm	50	53	60	64	74	90	101,5	115,5	139	167
Ø c ₁ H7	mm	65	74	84	102	124	152	190	230	285	370
Ø c ₂ min H7	mm	20	20	25	30	35	40	50	60	70	90
Ø d H7	mm	10 ... 20	10 ... 25	12 ... 30	15 ... 40	20 ... 50	25 ... 60	30 ... 70	40 ... 90	50 ... 100	70 ... 130
Ø e	mm	32	37	43	52	62	82	88	113	138	168
Ø g	mm	74	84	98	118	140	172	210	257	316	407
Ø h	mm	81	90	105	125	150	186	221	274	338	426
i airgap (clutch engaged)	mm	0,15 - 0,25	0,15 - 0,25	0,20 - 0,30	0,25 - 0,30	0,25 - 0,30	0,25 - 0,30	0,30 - 0,50	0,30 - 0,50	0,30 - 0,50	0,30 - 0,50
k / Ø m rough bored for dowel	mm	M5 / 4	M5 / 5	M6 / 6	M6 / 6	M8 / 8	M8 / 8	M10 / 10	M12 / 12	M16 / 16	M16 / 20
l ₁	mm	4	5	5	5	7	8	11	11	13	14
l ₂	mm	4	5	6	8	8	12	12	15	15	18
p ₁	mm	25	27,5	32	37	42	54	60	67	85	105
p ₂	mm	32	34	39	45	50	66	70	80	97	120
s	mm	40,5	42,5	48,5	50	60	72	83	94	116	141
u	mm	2,5	2,5	2,5	3	3	3	3,5	3,5	5	5
w / x	mm	22 / 54	22 / 53	22 / 49	22 / 45	22 / 40	30 / 75	30 / 64	40 / 84	40 / 71	40 / 59
Keyway DIN 6885 - 2	-	1	1	1	1	1	2	2	2	2	2

1) up to 60% of full torque rate 2) drop to 10% of full torque rate