



HIGH-TEMPERATURE. HIGH-PRESSURE WASHDOWN



190 **STORM**
weight indicator



Model 190
AC Power



Model 190DC
DC Power

Both the 190 and 190DC may utilize an optional rechargeable Lithium Ion battery.



Optional DC
Power Supply



CAPACITIVE TOUCH KEYS

Capacitance is the ability of a person to hold an electrical charge, so Cardinal's 190 unique capacitive touch keys allow the front of the panel to be constructed as a single piece. The keypad senses the operator's finger from the inside of the enclosure. There are no moving parts to wear out or exposed electronics. Red status lamps above each key provide a visual indication of keypresses, as shown here.



ULTRA-TOUGH ENCLOSURE

The combination of the rugged polycarbonate enclosure and capacitive touch keys provide total protection from sharp objects. The 190 is impact resistant for ultimate durability in harsh environments. The IP69K watertight, highly-durable enclosure provides you with the assurance of dependability that you require.

COLORZONE CHECKWEIGHING

ColorZONE is the solution for efficient time management during your checkweighing processes. The bright, vivid display, changes color automatically as the pre-assigned target weights are reached. You know immediately when you've hit the acceptable weight range. The 190 STORM displays amber for under weight, green for accepted weights, and bright red when weights exceed the upper weight limit. The target weights are easy to assign through the 190's capacitive touch keypad and can be changed quickly as different sized products are weighed.

OVER

192 lb
5

ACCEPT

190 lb
5

UNDER

188 lb
5

Cardinal's 190 STORM high-impact indicator is perfect for:

- Food Processing
- Chemical Industry
- Pharmaceutical
- Almost any harsh application environment

IP69K

With an IP69K rating, the 190's enclosure is designed for high pressure water jet cleaning (1450PSI) at high temperatures of up to 176° F / 80° C.

WASHDOWN

STORM

Model 190
WEIGHT INDICATOR

- Large 1-inch-high clearly-visible LCD
- Versatile power options: AC, DC, and rechargeable battery
- Built-in RS232 communications port
- Highest protection rating possible



LEGAL FOR TRADE

190 SPECIFICATIONS

Power Requirements:	100 to 240 VAC (50/60 Hz) at 0.4A Max. / 190DC: 10.5 to 30 VDC 1.0A Max.
Enclosure Type:	Thermoplastic IP69K wall or desk-mount
Enclosure Size:	9.4 inch W x 6.4 inch H x 3.7 inch D / 239 mm W x 163 mm H x 93 mm D
Operating Environment:	Temperature: 14 to 104 °F (-10 to +40 °C) Humidity: 90% non-condensing (maximum)
Display:	Six digit, seven segment, 1.0 inch high Backlit LCD
Transducer Excitation:	5.18 VDC
Signal Input Range:	0.5 mV min. to 40 mV max. (with dead load boost)
Number of Load Cells:	6 each, 350 OHM minimum resistance
Load Cell Cable Length:	1500 feet maximum. 30 feet maximum without sense lines <i>Consult factory for other requirements</i>
Division Value:	1, 2, or 5 x 10, 1, 0.1, 0.01, 0.001 commercial 0 to 99, non-commercial
Sensitivity:	NON-COMMERCIAL 0.15 uV/e COMMERCIAL 0.5uV/e (Class III/IIIL/IIHHD)
Scale Divisions:	NON-COMMERCIAL 100 to 240,000 COMMERCIAL 100 to 10,000 (Class III/IIIL/IIHHD)
Internal Resolution:	1 part in 16,777,216
Tare Capacity:	Scale Capacity
Sample Rate:	1 to 100 samples per second, selectable
Auto Zero Range:	0.5 or 1 through 9 divisions
Weighing Units:	Pounds, Ounces, Kilograms, Grams
Keypad:	Color Coded Capacitive Touch type, 7 keys
Standard I/O:	(1) bi-directional RS232
Approvals:	NTEP: 10-084 MEASUREMENT CANADA: AM-5804 OIML: Pending

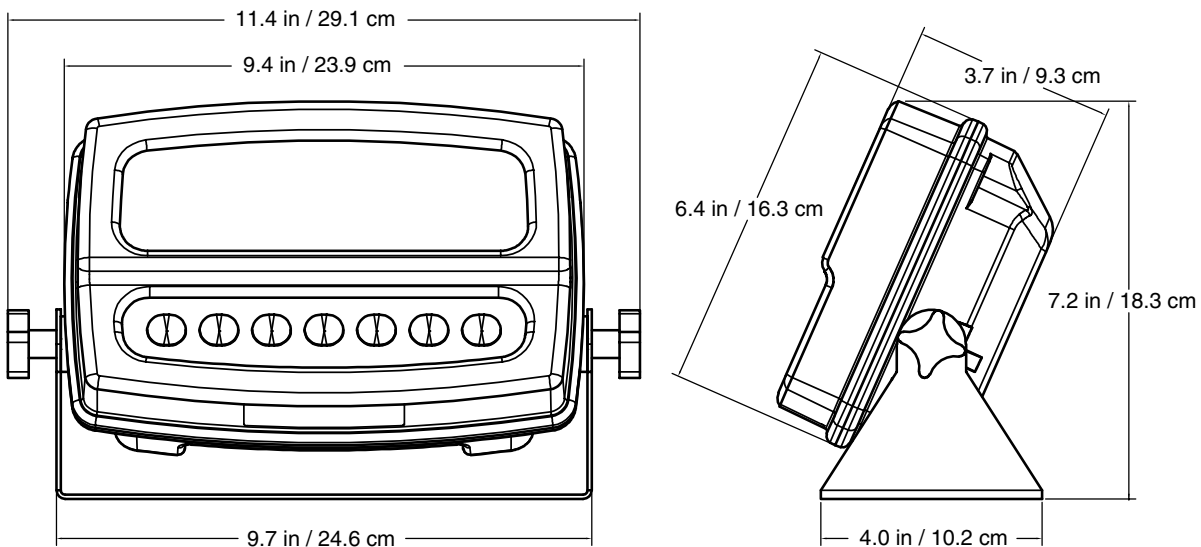

Cardinal Scale reserves the right to improve, enhance or modify features and specifications without prior notice. All registered trademarks are the property of their respective owners.

Cardinal
Cardinal Scale Manufacturing Co.
203 E. Daugherty, Webb City, MO 64870 USA
Ph: 417-673-4631 or 800-441-4237 • Fax: 417-673-5001
www.CardinalScale.com

SOLD BY:
KNORRING OY AB
Karvaamokuja 6
00380 HELSINKI
p. 09-56041
www.knorrning.fi knorrning@knorrning.fi

